

**ICC Evaluation Service, Inc.**  
[www.icc-es.org](http://www.icc-es.org)

**Business/Regional Office** ■ 5360 Workman Mill Road, Whittier, California 90601 ■ (562) 699-0543  
**Regional Office** ■ 900 Montclair Road, Suite A, Birmingham, Alabama 35213 ■ (205) 599-9800  
**Regional Office** ■ 4051 West Flossmoor Road, Country Club Hills, Illinois 60478 ■ (708) 799-2305

**DIVISION: 06—WOOD AND PLASTICS**  
**Section: 06090—Wood and Plastic Fastenings**

**REPORT HOLDER:**

**SFS INTEC, INC.**  
**POST OFFICE BOX 6326**  
**SPRING STREET AND VAN REED ROAD**  
**WYOMISSING, PENNSYLVANIA 19610**  
**(610) 376-5751**  
[www.sfsintecusa.com](http://www.sfsintecusa.com)

**EVALUATION SUBJECT:**

**LOG SCREW AND LOG SCREW MAX LOG HOME FASTENERS**

**1.0 EVALUATION SCOPE**

**Compliance with the following codes:**

- 2003 *International Building Code*® (IBC)
- 2003 *International Residential Code*® (IRC)

**Properties evaluated:**

Structural

**2.0 USES**

The Log Screw and Log Screw MAX Log Home Fasteners described in this report are alternate dowel-type threaded fasteners less than 1/4 inch (6.4 mm) in diameter used for wood-to-wood connections.

**3.0 DESCRIPTION**

**3.1 General:**

The Log Screw and Log Screw MAX described in this report depart from the ANSI B18.2.1 and B18.6.1 standards in thread design, exceed the bending yield strengths documented in Table 6 of the American Forest & Paper Association (AF&PA) *Technical Report #12*, and may be installed without lead holes typically required by the AF&PA *National Design® Specification for Wood Construction (NDS®)*. These fasteners are manufactured using a standard cold-forming process. The fasteners have a proprietary coating with a lubricious top coat. The fasteners have a hex-head design with an integral washer, rolled threads and relief wings located directly above the threads and transition zone. The fasteners are packaged with a total of 250 screws to a box, and each box is provided with a 5/16-inch (7.9 mm) hex driver.

**3.2 Log Screw:**

The Log Screw is a 10-inch-long (254 mm) fastener having a root diameter of 0.1675 inch (4.3 mm) and 7.5 threads per inch (0.3 threads per mm), for a total thread length of 2.375 inches (60 mm) including the gimlet point.

**3.3 Log Screw MAX:**

The Log Screw MAX is a 10-inch-long (254 mm) fastener having a root diameter of 0.2045 inch (5.2 mm) and 7.5 threads per inch (0.3 threads per mm), for a total thread length of 3.0 inches (76 mm) including the self-drilling point.

**3.4 Materials:**

The fasteners are made of carbon steel grade 10B18 wire, conforming to ASTM A510, with a minimum ultimate tensile strength of 60 ksi (414 Mpa). The steel is heat-treated for hardening. The allowable bending yield strength, tensile strength and shear strength of the fasteners are listed in Table 1 of this report.

**4.0 DESIGN AND INSTALLATION**

**4.1 Design:**

Design values for dowel bearing strengths are specified in Table 2. Design values for withdrawal connections are specified in Table 3. Design values for pull-through are specified in Table 4. Design values for lateral resistance in wood-to-wood connections loaded parallel and perpendicular to the grain are specified in Table 5.

**4.2 Installation:**

The Log Screw and Log Screw MAX must be installed with a 1/2-inch (12.7 mm), high-torque drill (0 to 1000 RPM) using the 5/16-inch (7.9 mm) hex driver provided with each box of fasteners. The fastener head and fixed flat washer are countersunk into the surface of the wood member. The fastener may be installed without the use of a lead hole. Fastener spacing, and edge and end distance requirements, are as specified in Table 6.

**5.0 CONDITIONS OF USE**

The Log Screw and Log Screw MAX described in this report comply with, or are suitable alternatives to what is specified in, those codes listed in Section 1.0 of this report, subject to the following conditions:

- 5.1** When the capacity of a connection is controlled by the metal strength of the fastener, rather than the strength of the wood, the allowable strength of the connection shall not be permitted to be multiplied by the adjustment factors specified in the NDS®.
- 5.2** The connections must be designed to comply with Appendix E of the NDS®.
- 5.3** Corrosion resistance of fasteners installed in chemically treated wood is outside the scope of this report.

**6.0 EVIDENCE SUBMITTED**

Data in accordance with the ICC-ES Acceptance Criteria for Alternative Dowel-type Threaded Fasteners Less Than 1/4 Inch in Diameter (AC233), dated February 2006.

\*Corrected December 2006

ES REPORTS™ are not to be construed as representing aesthetics or any other attributes not specifically addressed, nor are they to be construed as an endorsement of the subject of the report or a recommendation for its use. There is no warranty by ICC Evaluation Service, Inc., express or implied, as to any finding or other matter in this report, or as to any product covered by the report.



## 7.0 IDENTIFICATION

Each package/container of fasteners bears a label noting the SFS intec, Inc., name, product designation "Log Screw" or

"Log Screw MAX," and the ICC-ES evaluation report number (ESR-1876). Markings on the hex-head consist of the SFS intec, Inc., logo reading "SFS" (see Figure 1).

**TABLE 1—FASTENER SPECIFICATIONS**

FASTENER DESIGNATION	OVERALL LENGTH (inches) <sup>1</sup>	LENGTH OF THREAD (inches) <sup>2,5</sup>	UNTHREADED SHANK DIAMETER (inch)	MINOR THREAD DIAMETER (inch) <sup>3</sup>	STEEL STRENGTH		
					Bending Yield Strength, $F_{yB}$ (psi) <sup>4,6</sup>	Tension (psi)	Shear (psi)
Log Screw	10	2.375	0.189	0.172 [0.175 - 0.160]	213,737	56,308	34,700
Log Screw MAX	10	3.0	0.230	0.204 [0.212 - 0.197]	228,791	56,222	34,032

For **SI**: 1 inch = 25.4 mm, 1 psi = 6.89 kPa.

<sup>1</sup>Overall fastener length is measured from underside of head washer to bottom of tip.

<sup>2</sup>Length of thread includes tip. See Figures 1 and 2.

<sup>3</sup>Minor thread diameters are shown with manufacturing tolerances in brackets [ ].

<sup>4</sup>Bending yield strength determined in accordance with ASTM D 1575 using the minor thread diameter.

<sup>5</sup>Fastener installation and design values require complete threaded portion to be embedded in the main member.

**TABLE 2—DOWEL BEARING STRENGTH<sup>1,2</sup>**

FASTENER DESIGNATION	DIRECTION OF LOADING	CALCULATED DOWEL BEARING STRENGTH PER REGRESSION EQUATIONS (psi) FOR SPECIFIC GRAVITIES OF:						
		0.67	0.55	0.50	0.46	0.43	0.36	0.31
Log Screw	Parallel to grain	7504	6160	5570	5093	4762	4032	3472
	Perpendicular to grain	7851	5897	5086	4477	4068	3190	2568
Log Screw MAX	Parallel to grain	7504	6160	5600	5103	4757	4032	3472
	Perpendicular to grain	7117	5346	4656	4125	3741	2891	2328
Wet Service Factor, $C_m$ , for lateral loads	Parallel to grain	0.7	0.7	0.7	0.7	0.7	0.7	0.7
	Perpendicular to grain	0.7	0.7	0.7	0.7	0.7	0.7	0.7

For **SI**: 1 psi = 6.89 kPa.

<sup>1</sup>Test results are the five-percent offset value.

<sup>2</sup>Values determined with diameters of 0.172 inch for Log Screw and 0.204 for the Log Screw MAX.

**TABLE 3—WITHDRAWAL DESIGN VALUE ( $W$ )**

FASTENER DESIGNATION	THREAD LENGTH <sup>2</sup> , $L$ (inches)	$P$ (lbf/in) FOR SPECIFIC GRAVITIES OF <sup>1,3</sup> :						
		0.67	0.55	0.50	0.46	0.43	0.36	0.31
Log Screw	2.375	264	196	170	150	136	104	83
Wet Service Factor, $C_m$ , for withdrawal loads		0.6	0.7	0.7	0.7	0.7	0.7	0.7
Log Screw MAX	3	300	223	193	170	154	118	94
Wet Service Factor, $C_m$ , for withdrawal loads		0.6	0.6	0.6	0.6	0.6	0.7	0.7
NDS equation used to calculate design values		11.2-1	11.2-1	11.2-1	11.2-1	11.2-1	11.2-1	11.2-1

For **SI**: 1 inch = 25.4 mm, 1 lbf/in = 175.1 N/m.

<sup>1</sup>Values shall be multiplied by all applicable adjustment factors (see NDS).

<sup>2</sup>Embedded thread length is that portion held by the main member (including tip).

<sup>3</sup>Tabulated Withdrawal Design Values ( $W$ ) are in pounds per inch of thread penetration into side grain or member.

TABLE 4—PULL-THROUGH DESIGN VALUES<sup>1</sup>

FASTENER DESIGNATION	THREAD LENGTH <sup>2</sup> , <i>L</i> (inches)	<i>P</i> (lbf/in of wood) FOR SPECIFIC GRAVITIES OF <sup>1,3</sup> :						
		0.67	0.55	0.50	0.46	0.43	0.36	0.31
Log Screw	2.375	432	241	188	157	140	124	131
Wet Service Factor, <i>C<sub>m</sub></i>		0.7	0.7	0.7	0.7	0.7	0.7	0.6
Log Screw MAX	3	630	386	315	268	237	178	145
Wet Service Factor, <i>C<sub>m</sub></i>		.06	0.6	0.6	0.6	0.6	0.7	0.7

For **SI**: 1 inch = 25.4 mm, 1 lbf/in = 175.1 N/m.

<sup>1</sup>Values shall be multiplied by all applicable adjustment factors (see NDS).

<sup>2</sup>Embedded thread length is that portion held by the main member (including tip).

<sup>3</sup>Tabulated pull-through design values (*P*) are in pounds per inch through side member.

TABLE 5A—LATERAL DESIGN VALUES (*Z*) FOR SINGLE SHEAR (TWO-MEMBER) CONNECTIONS WITH LOADING PARALLEL TO GRAIN<sup>1,2</sup>

FASTENER DESIGNATION	SIDE MEMBER THICKNESS, <i>t<sub>s</sub></i> (inches)	FASTENER PENETRATION, <i>p</i> (inches) <sup>3,5</sup>	<i>Z</i> (lbs.) FOR SINGLE SHEAR (TWO-MEMBER) CONNECTIONS LOADED PARALLEL TO GRAIN FOR SPECIFIC GRAVITIES OF <sup>4</sup> :						
			0.67	0.55	0.50	0.46	0.43	0.36	0.31
Log Screw	7.625	2.5	308	279	265	254	245	226	210
Log Screw MAX	7.000	3.0	392	355	339	323	312	287	267

For **SI**: 1 inch = 25.4 mm, 1 lbf/in = 175.1 N/m.

<sup>1</sup>Values shall be multiplied by all applicable adjustment factors (see NDS).

<sup>2</sup>Tabulated design values (*z*) are in pounds per fastener into sawn lumber or SCL with both members of identical specific gravity.

<sup>3</sup>Fastener penetration is that portion held by the main member (including tip).

<sup>4</sup>For sawn lumber of SCL (structural composite lumber) with both members of identical specific gravity. SCL includes laminated veneer lumber (LVL) and parallel strand lumber (PSL).

TABLE 5B—LATERAL DESIGN VALUES (*Z*) FOR SINGLE SHEAR (TWO-MEMBER) CONNECTIONS WITH LOADING PERPENDICULAR TO GRAIN<sup>1,2</sup>

FASTENER DESIGNATION	SIDE MEMBER THICKNESS, <i>t<sub>s</sub></i> (inches)	FASTENER PENETRATION, <i>p</i> (inches) <sup>2,4</sup>	<i>Z</i> (lbs.) FOR SINGLE SHEAR (TWO-MEMBER) CONNECTIONS LOADED PERPENDICULAR TO GRAIN FOR SPECIFIC GRAVITIES OF <sup>3</sup> :						
			0.67	0.55	0.50	0.46	0.43	0.36	0.31
Log Home Fastener	7.5	2.5	315	273	254	238	227	201	187
Log Home Fastener Max	7.0	3.0	382	331	309	291	277	243	218

For **SI**: 1 inch = 25.4 mm, 1 lbf/in = 175.1 N/m.

<sup>1</sup>Values shall be multiplied by all applicable adjustment factors (see NDS).

<sup>2</sup>Tabulated design values (*z*) are in pounds per fastener into sawn lumber or SCL with both members of identical specific gravity.

<sup>3</sup>Fastener penetration length is that portion held by the main member (including tip).

<sup>4</sup>For sawn lumber of SCL with both members of identical specific gravity. SCL includes LVL and PSL.

TABLE 6—FASTENER SPACING, EDGE AND END DISTANCES

CONNECTION GEOMETRY/CRITERIA	DIAMETERS <sup>1</sup> ( <i>D</i> )	LOG SCREW (inch)	LOG SCREW MAX (inch)
Minimum edge distance (2.5 <i>D</i> per NDS Commentary Table C11.4-1)	8	1½	1⅞
Minimum edge distance from loaded edge (4 <i>D</i> per NDS Table 11.5.1A)	8	1½	1⅞
Minimum end distance, tension load parallel to grain (per NDS commentary Table C11.4-1)	15	2⅞	3½
Minimum end distance, compression load parallel to grain (per NDS commentary Table C11.4-1)	10	1 <sup>15</sup> / <sub>16</sub>	2 <sup>15</sup> / <sub>16</sub>
Spacing (pitch) between fasteners in a row, parallel to grain	15	2⅞	3½
Spacing (pitch) between fasteners in a row, perpendicular to grain	10	1 <sup>15</sup> / <sub>16</sub>	2 <sup>5</sup> / <sub>16</sub>
Spacing (gage) between rows of fasteners, in line	5	1	1 <sup>3</sup> / <sub>16</sub>
Spacing (gage) between rows of fasteners, staggered	2.5	½	5/8
Minimum penetration into the main member for single shear connections	13	2½	3

For **SI**: 1 inch = 25.4 mm.

<sup>1</sup>Unthreaded shank diameter.

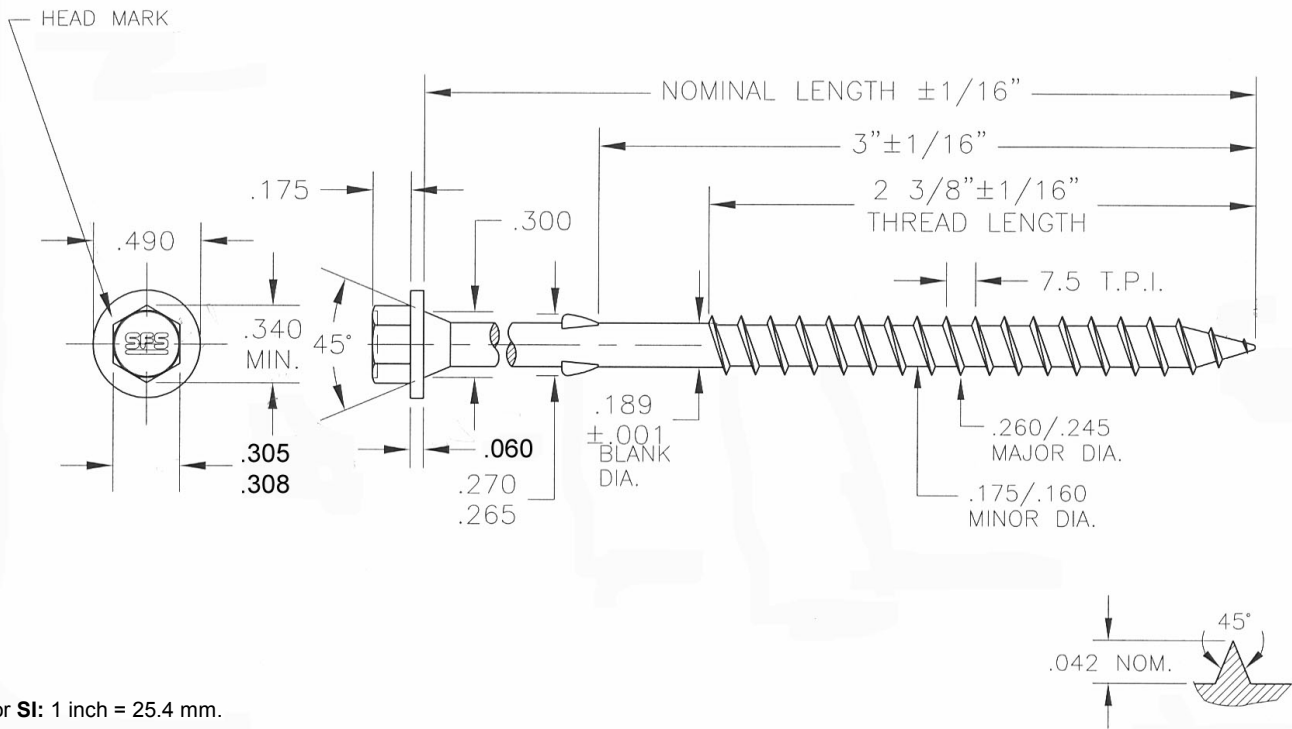

For SI: 1 inch = 25.4 mm.

FIGURE 1—LOG SCREW

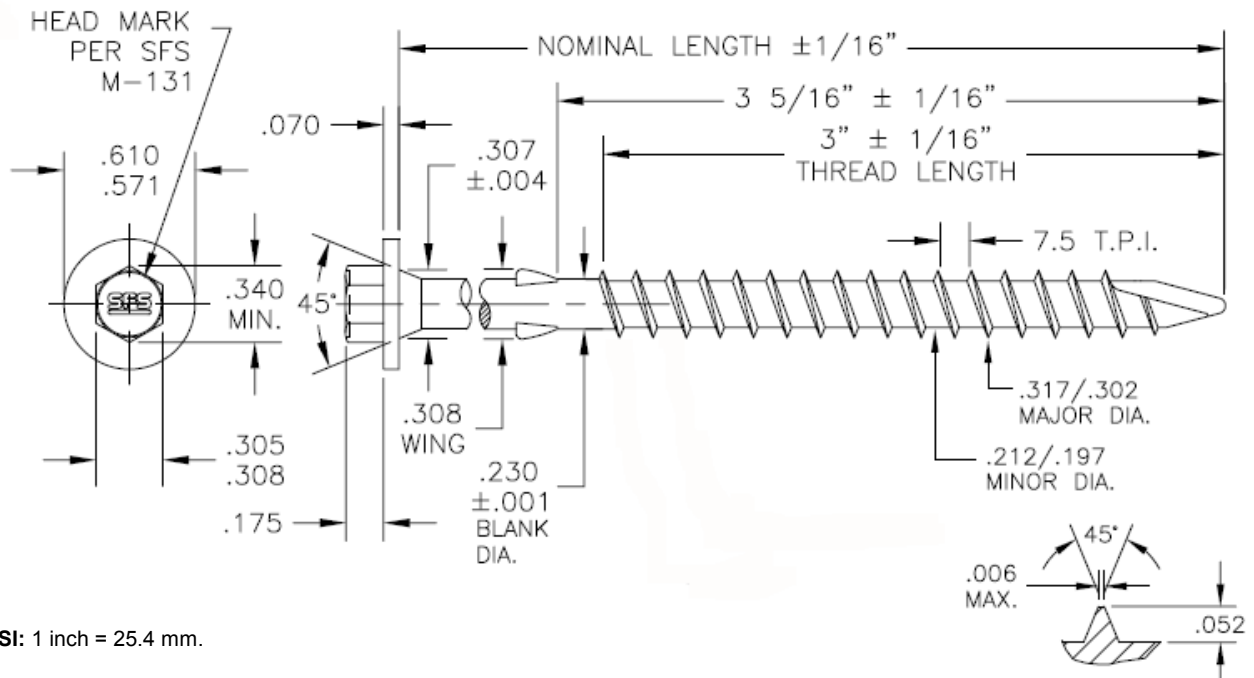

For SI: 1 inch = 25.4 mm.

FIGURE 2—LOG SCREW MAX